

High Accuracy Differential Pressure Transducer Model CPT8900



High Accuracy Differential Pressure Transducer Model CPT8900

EN Operating instructions model CPT8900

© 2025, Mensor, LP. All rights reserved.

Mensor is a registered trademark of Mensor, LP.

All other brand and product names are trademarks or registered trademarks of their respective companies.

Prior to starting any work, read the operating instructions!

Keep for later use!

0020962001A 09/2025 EN

Contents

EN

1. General Information	5
1.1 Warranty	5
1.2 Radio Frequency Emission Notices	6
1.2.1 FCC Emission Notice	6
1.2.2 CE Emission Notice	6
1.3 Software License Agreement	6
1.4 Mensor Service Plus	6
1.4.1 After the Warranty	6
1.4.2 Calibration Services	6
1.4.3 Certifications and Accreditations	6
2. Short Overview	7
2.1 Features	7
2.2 Scope of Delivery	7
3. Safety	8
3.1 Explanation of Symbols	8
3.2 Intended Use	8
3.3 Improper Use	8
3.4 Responsibility of the Operator	9
3.5 Personnel Qualification	9
3.6 Personal Protective Equipment	10
3.7 Labeling, Safety Marks	10
3.7.1 Product Label	10
3.7.2 Symbols	11
3.8 Warnings and Cautions	11
4. Transport, Packaging and Storage	12
4.1 Transport	12
4.2 Packaging and storage	12
5. Installation	13
5.1 Pressure Connections	13
5.2 Safety Relief Valves	13
5.3 Power/Communication Cables	13
5.4 Pressure Media	13
5.5 Mounting	14
5.6 Electrical Connections	16
5.6.1 RS-232/RS-485 Versions	16
5.6.2 USB Versions	16
6. Operation	17
6.1 General Operation	17
6.2 USB Driver	17
6.3 LED Colors	17
6.4 Command and Query Format	17
6.4.1 RS-485 Command and Query Format	17
6.4.2 RS-232 and USB Command and Query Format	17
6.4.3 Command Error Detection and Debugging	18
6.5 CPT8900 Commands and Queries	18
6.5.1 Command Structure Topology	21
6.5.2 Password Protection	21
6.5.3 Units	22
6.5.4 Default Command	22

0020962001A_09/2025 EN

6.6	Transducer Outputs	23
6.6.1	Output Mode 0 - Query Mode	23
6.6.2	Output Mode 1 - Continuous Mode after Pressure Calculation	24
6.6.3	Output Mode 2 - Continuous Mode at Specified Time Interval	25
6.6.4	Output Mode 3 - Burst Mode	25
6.6.5	Rate Calculation	25
6.6.6	Checksum Calculation	26
6.7	Error Codes	26
7.	Maintenance and Recalibration	27
7.1	Maintenance	27
7.1.1	Beyond the Warranty	27
7.2	Recalibration	27
7.2.1	Calibration Services by Mensor or WIKA worldwide	27
7.2.2	Environment	28
7.2.3	Pressure Standards	28
7.2.4	Media	28
7.2.5	Setup.	28
7.2.5.1	Differential Sensor Calibration Setup	28
7.2.5.2	Static Sensor Calibration Setup	29
7.2.6	Calibration & Communication Software	30
8.	Dismounting, Return and Disposal	31
8.1	Dismounting	31
8.2	Return	32
8.3	Disposal.	32
9.	Specifications	33
9.1	Measurement Specification	33
9.2	General Specification	34
9.3	Dimensions in in (mm)	35
10.	Accessories	37
10.1	Fittings	37
10.2	Accessories	37

1. General Information

- The CPT8900 High Accuracy Differential Pressure Transducer described in the operating instructions has been designed and manufactured using state-of-the-art technology. All components are subject to stringent quality and environmental criteria during production. Our management systems are certified to ISO 9001 and ISO 14001.
- These operating instructions contain important information on handling the instrument. Working safely requires that all safety instructions and work instructions are observed.
- Observe the relevant local accident prevention regulations and general safety regulations for the instrument's operating range.
- The operating instructions are part of the instrument and must be kept in the immediate vicinity of the instrument and readily accessible to skilled personnel at any time. Pass the operating instructions onto the next operator or owner of the instrument.
- Skilled personnel must have carefully read and understood the operating instructions prior to beginning any work.
- The general terms and conditions contained in the sales documentation shall apply.
- Subject to technical modifications.
- Factory calibrations are carried out in accordance with international standards.

Further information:

Mensor Corporation

- Address: 201 Barnes Dr., San Marcos, TX 78666
 - Internet address: www.mensor.com
 - Relevant data sheet: CT 25.15
 - Application consultant: Tel.: (+1) 512-396-4200
(+1) 800-984-4200 (USA only)
- | | |
|--|---|
| sales@mensor.com | New Equipment RFQs, questions and PO placement |
| techservices@mensor.com | Calibration and repair RFQs and POs for fielded equipment |
| tech.support@mensor.com | Technical questions or fielded equipment |

WIKA Alexander Wiengand SE & Co. KG

- Address: Alexander Wiegand-Straße
63911 Klingenberg, Germany
- Internet address: www.wika.de / www.wika.com
- Relevant data sheet: CT 25.15
- Application consultant: Tel.: (+49) 9372/132-5015
Fax: (+49) 9372/132-8767
E-Mail: CTsales@wika.com

1.1 Warranty

All products manufactured by Mensor are warranted to be free of defects in workmanship and materials for a period of two year from the date of shipment. No other express warranty is given, and no affirmation of Seller, by words or actions, shall constitute a warranty. SELLER DISCLAIMS ANY IMPLIED WARRANTIES OF MERCHANTABILITY OR FITNESS FOR ANY PARTICULAR PURPOSES WHATSOEVER. If any defect in workmanship or material should develop under conditions of normal use and service within the warranty period, repairs will be made at no charge to the original purchaser, upon delivery of the product(s) to the factory, shipping charges prepaid. If inspection by Mensor or its authorized representative reveals that the product was damaged

by accident, alteration, misuse, abuse, faulty installation or other causes beyond the control of Mensor, this warranty does not apply. The judgment of Mensor will be final as to all matters concerning condition of the product, the cause and nature of a defect, and the necessity or manner of repair. Service, repairs or disassembly of the product in any manner, performed without specific factory permission, voids this warranty.

MENSOR MAKES NO WARRANTY OF ANY KIND WITH REGARD TO THIS MANUAL, INCLUDING, BUT NOT LIMITED TO, THE IMPLIED WARRANTIES OF MERCHANTABILITY AND FITNESS FOR A PARTICULAR PURPOSE. Mensor shall not be liable for errors contained herein or for incidental or consequential damages in connection with the furnishing, performance, or use of this material.

1.2 Radio Frequency Emission Notices



USE SHIELDED CABLES TO CONNECT EXTERNAL DEVICES TO THIS INSTRUMENT TO MINIMIZE RF RADIATION

1.2.1 FCC Emission Notice

This equipment has been tested and found to comply with the limits for a Class B digital device, pursuant to part 15 of the FCC Rules. These limits are designed to provide reasonable protection against harmful interference when the equipment is operated in a residential environment. This equipment generates, uses, and can radiate radio frequency energy and, if not installed and used in accordance with the instruction manual, may cause harmful interference to radio communications.

1.2.2 CE Emission Notice

This equipment is of the emission class B, intended for operation in industrial, residential or commercial environments.

1.3 Software License Agreement

This product contains intellectual property, i.e. software programs, that are licensed for use by the end user/customer (hereinafter “end user”).

This is not a sale of such intellectual property.

The end user shall not copy, disassemble or reverse compile the software program.



The software programs are provided to the end user “as is” without warranty of any kind, either express or implied, including, but not limited to, warranties of merchantability and fitness for a particular purpose. The entire risk of the quality and performance of the software program is with the end user.

Mensor and its suppliers shall not be held to any liability for any damages suffered or incurred by the end user (including, but not limited to, general, special, consequential or incidental damages including damages for loss of business profits, business interruption, loss of business information and the like), arising from or in connection with the delivery, use or performance of the software program.

1.4 Mensor Service Plus

1.4.1 After the Warranty

Mensor’s concern with the performance of this instrument is not limited to the warranty period. We provide complete repair, calibration and certification services after the warranty for a nominal fee.

1.4.2 Calibration Services

In addition to servicing our own products Mensor can perform a complete pressure calibration service, up to 72,500 psi (5000 bar), for all of your pressure instruments. This service includes an accredited calibration.

1.4.3 Certifications and Accreditations

Mensor is registered to ISO 9001:2015. The calibration program at Mensor is accredited by A2LA, as complying with both the ISO/IEC 17025:2017 and the ANSI/NCSL Z540-1-1994 standards.

2. Short Overview

The CPT8900 High Accuracy Differential Pressure Transducer is a high accuracy digital output pressure transducer comprised of two separate sensors. This configuration incorporates an absolute pressure sensor for measuring static pressures and a differential sensor.

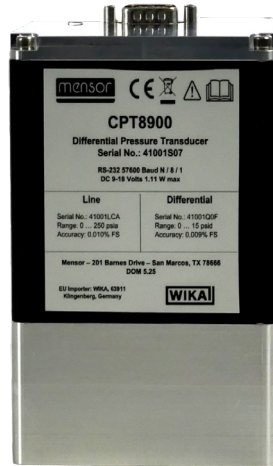

Figure 2.1

2.1 Features

Here is a short list of significant features designed into the CPT8900:

- Differential pressure accuracy up to 0.01% FS fully corrected for line pressure and temperature effects
- RS-232, RS-485, or USB interfaces
- Multiple output formats that can provide the outputs of both pressure sensors
- Built-in altitude and airspeed calculations
- Programmable alarm limits on pressures and temperatures
- Clean, dry, non-corrosive, non-oxidizing media
- User selectable units

2.2 Scope of Delivery

- High Accuracy Differential Pressure Transducer model CPT8900
- RS-232/RS-485: Power cord with 1.5 m (5 ft) length (optional)
- USB: Cable 1 m/3 m (3 ft/10 ft) length (optional)
- Operating instruction
- Factory calibration certificate
- Selected fittings
- Dual differential relief valve (optional)

3. Safety

3.1 Explanation of Symbols

EN



DANGER!

... indicates a directly dangerous situation resulting in serious injury or death, if not avoided.



WARNING!

... indicates a potentially dangerous situation that can result in serious injury or death, if not avoided.



CAUTION!

... indicates a potentially dangerous situation that can result in light injuries or damage to property or the environment, if not avoided.



DANGER!

... identifies hazards caused by electrical power. Should the safety instructions not be observed, there is a risk of serious or fatal injury.



WARNING!

... indicates a potentially dangerous situation that can result in burns, caused by hot surfaces or liquids, if not avoided.



Information

... points out useful tips, recommendations and information for efficient and trouble-free operation.

3.2 Intended Use

The CPT8900 pressure transducer is designed to measure differential pressure with extreme accuracy as a stand-alone device or as incorporated in OEM-type applications. It is characterized over a wide temperature range and is designed to correct for any static line pressure effects across the transducer's static range.

3.3 Improper Use



WARNING!

Injuries through improper use

Improper use of the instrument can lead to hazardous situations and injuries.

- ▶ Do not use the transducer within hazardous areas
- ▶ Do not use the transducer with materials and mixtures of the group 1 (hazardous fluids) according Regulation (EC) no. 1272/2008.
- ▶ Do not use the transducer with oxygen as a medium
- ▶ Do not attempt to disassemble the transducer

Any use beyond or different than the intended use is considered improper use.

0020962001A 09/2025 EN

3.4 Responsibility of the Operator

The instrument is used in the industrial sector. The operator is therefore responsible for legal obligations regarding safety at work.

The safety instructions within these operating instructions, as well as the safety, accident prevention and environmental protection regulations for the application area must be maintained.

The operator is obliged to maintain the product label in a legible condition.

The operator must ensure that:

- Mechanical vibration, mechanical shock are minimized
- The transducer is installed in areas without soot, vapor, dust and corrosive gases
- The transducer is not used in hazardous environments, flammable atmospheres
- The operating personnel are regularly instructed in all topics regarding work safety, first aid and environmental protection and know the operating instructions and in particular, the safety instructions contained therein
- The transducer is suitable for the particular application in accordance with its intended use
- Personal protective equipment is available

3.5 Personnel Qualification



WARNING!

Risk of injury should qualification be insufficient

Improper handling can result in considerable injury and damage to equipment.

- ▶ The activities described in these operating instructions may only be carried out by skilled personnel who have the qualifications described below.

Skilled personnel

Skilled personnel, authorized by the operator, are understood to be personnel who, based on their technical training, knowledge of measurement and control technology and on their experience and knowledge of country-specific regulations, current standards and directives, are capable of carrying out the work described and independently recognizing potential hazards.

Operating personnel

The personnel trained by the operator are understood to be personnel who, based on their education, knowledge and experience, are capable of carrying out the work described and independently recognizing potential hazards.

Special knowledge for working with instruments for hazardous areas:

The skilled (electrical) personnel must have knowledge of ignition protection types, regulations and provisions for equipment in hazardous areas.

Special operating conditions require further appropriate knowledge, e.g. of aggressive media.

3.6 Personal Protective Equipment

The personal protective equipment is designed to protect the skilled personnel from hazards that could impair their safety or health during work. When carrying out the various tasks on and with the instrument, the skilled personnel must wear personal protective equipment.

EN

Follow the instructions displayed in the work area regarding personal protective equipment!

The requisite personal protective equipment must be provided by the operating company.



Wear safety goggles!

Protect eyes from flying particles and liquid splashes.



Wear a protective helmet!

Protects the head from falling objects.



Wear safety shoes!

Protect feet from falling objects or objects lying around, as well as against toxic or hazardous liquids and aggressive media.

3.7 Labeling, Safety Marks

3.7.1 Product Label

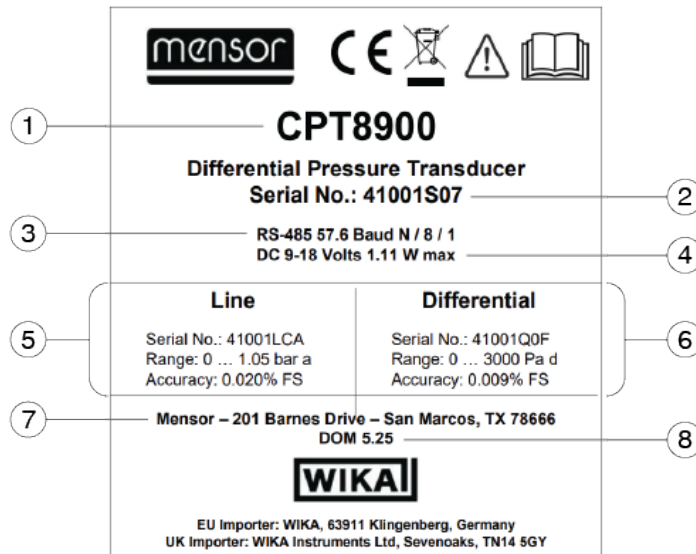

① Model

② Transducer Serial Number

③ Communications

④ Power Requirements

⑤ Static Transducer SN, Range & Accuracy

⑥ Differential Transducer SN, Range & Accuracy

⑦ Origin / Manufacturer

⑧ Date of Manufacture (M. YR)

3.7.2 Symbols



Before mounting and commissioning the instrument, ensure you read the operating instructions!



CE, Communauté Européenne
Instruments bearing this mark comply with the relevant European directives.



This marking on the instruments indicates that they must not be disposed of in domestic waste. The disposal is carried out by return to the manufacturer or by the corresponding municipal authorities (see EU directive 2012/19/EU).

3.8 Warnings and Cautions



WARNING!
HIGH PRESSURE! High pressure gases are potentially hazardous. Energy stored in these gases and liquids can be released suddenly and with extreme force. High pressure systems should be assembled and operated only by personnel who have been trained in proper safety practices.



WARNING!
NOT EXPLOSION PROOF! Installation of this instrument in an area requiring devices rated as intrinsically safe is not recommended.



WARNING!
POSSIBLE INJURY! The tubing, valves, and other apparatus attached to the gauge must be adequate for the maximum pressure which will be applied, otherwise physical injury to the operator or bystanders is possible.



CAUTION
USE THE PROPER PRESSURE MEDIUM! Only use media compatible with materials of construction as specified. This transducer is not designed for oxygen use.



CAUTION
As with most sensitive electronic equipment, switch the power switch off before connecting or disconnecting to a power source to prevent data loss. Do not position the equipment so that it is difficult to disconnect the AC power cord.



WARNING!
Detachable main power supply cord with inadequate ratings should not be used. See Section 9.2 Specifications for power ratings.



WARNING!
RISK OF FIRE OR ELECTRIC SHOCK! Do not operate the supplied RS-232/RS-485 wall adapter outside its specified temperature range (0 °C to 40 °C). Doing so may result in overheating, malfunction, or safety hazards.

Additional Warning and Caution notices are found throughout this manual.

4. Transport, Packaging and Storage

4.1 Transport

Check the CPT8900 for any damage that may have been caused by transport. Obvious damage must be reported immediately.



CAUTION!

Damage through improper transport

- While unlikely, with improper transport, damage can occur. When unloading packed goods upon delivery as well as during internal transport, proceed carefully and observe the symbols on the packaging.
- If the instrument is transported from a cold into a warm environment, the formation of condensation may result in instrument malfunction. Before putting it back into operation, wait for the instrument temperature and the room temperature to equalize.

4.2 Packaging and Storage

Permissible conditions at the place of storage

- Storage Temperature: -40 ... 85°C
- Humidity: 5 ... 95% relative humidity (no condensation)

Avoid exposure to the following factors:

- Direct sunlight or proximity to hot objects
- Mechanical vibration, excessive mechanical shock
- Soot, vapor, dust and corrosive gases
- Hazardous environments, flammable atmospheres

5. Installation

Personnel: Skilled electrical personnel



WARNING!

READ THESE INSTRUCTIONS BEFORE INSTALLATION!
Only use original parts (see Chapter 10 "Accessories").



WARNING!

Physical injuries and damage to property and the environment caused by hazardous media

Upon contact with hazardous media (e.g. oxygen, acetylene, flammable or toxic substances), harmful media (e.g. corrosive, toxic, carcinogenic, radioactive), and also with refrigeration plants and compressors, there is a danger of physical injuries and damage to property and the environment.

Should a failure occur, aggressive media with extremely high temperature and under high pressure or vacuum may be present at the instrument.

- ▶ For these media, in addition to all standard regulations, the appropriate existing codes or regulations must also be followed.
- ▶ Wear the requisite protective equipment (see Chapter 3.6 "Personal Protective Equipment").



CAUTION

Damage to the Instrument

When working on open electrical circuits (printed circuit boards) there is a risk of damaging sensitive electronic components through electrostatic discharge.

- ▶ The correct use of grounded working surfaces and personal armbands is required.

5.1 Pressure Connections

The CPT8900 has 7/16-20 SAE ports for fittings. Different adapter fittings can be selected at time of purchase. Internally, the static pressure is pneumatically tied to the reference of the differential sensor. Care must be taken when calibrating the static pressure sensor as it should be externally tied to the differential pressure side to apply equal pressures to the pressure and reference ports of the differential sensor. Mensor has a calibration adapter is available to aid in calibrations.

5.2 Safety Relief Valves

Mensor has dual-differential relief valves available to protect the differential sensor against overpressure. It is offered with and without a relief valve to atmosphere to protect the static sensor against overpressure.

5.3 Power/Communication Cables

For RS-232/RS-485 models, an optional communications cable with power supply is available. Alternatively, a 9-pin Dsub can be used using the electrical pinouts in Section 5.6. For USB models, the transducer communicates and is powered using a USB micro B cable.

5.4 Pressure Media

A media compatible with the wetted parts of the transducer must be used. Only clean, dry, non-corrosive, non-oxidizing media may be used with this transducer.



CAUTION

USE THE PROPER PRESSURE MEDIUM! Only use media compatible with materials of construction as specified .
This transducer is not designed for oxygen use.

Installation

5.5 Mounting

The transducer may be mounted via its mounting holes with dimensions as shown in Figure 5.5A (without relief valve) and Figure 5.5B (with relief valve). Having the sensor oriented in a position other than vertical (with the communications cable at the top) might cause a slight zero shift than can be removed by re-zeroing the transducer.

Note: Figures shown with arbitrary communication connection.

Without Relief Valve

Side

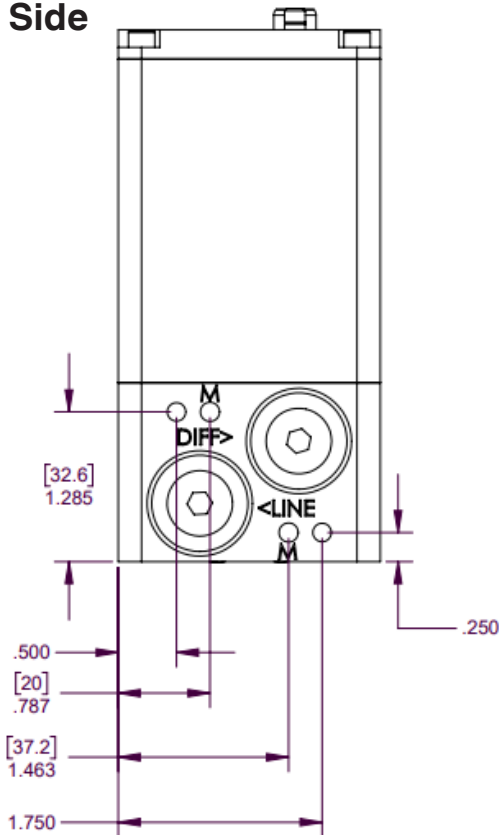

Back

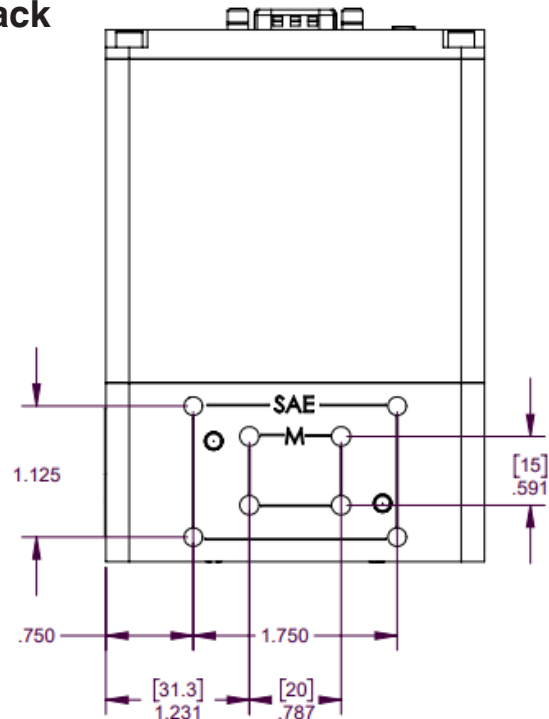

Bottom

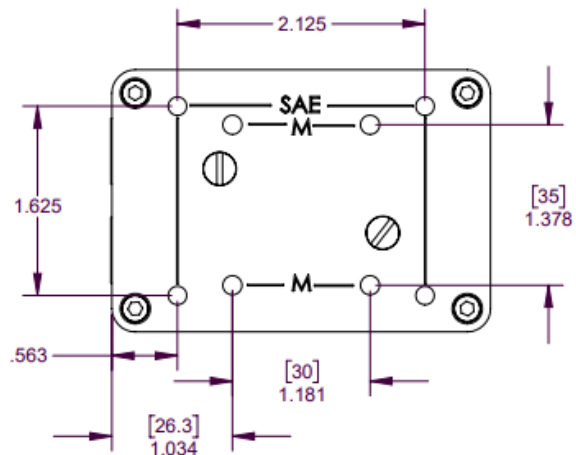

Note: Opposite side of transducer follows above dimensions, but will be mirrored across the y-axis

Figure 5.5A Mounting diagram without relief valve

With Relief Valve

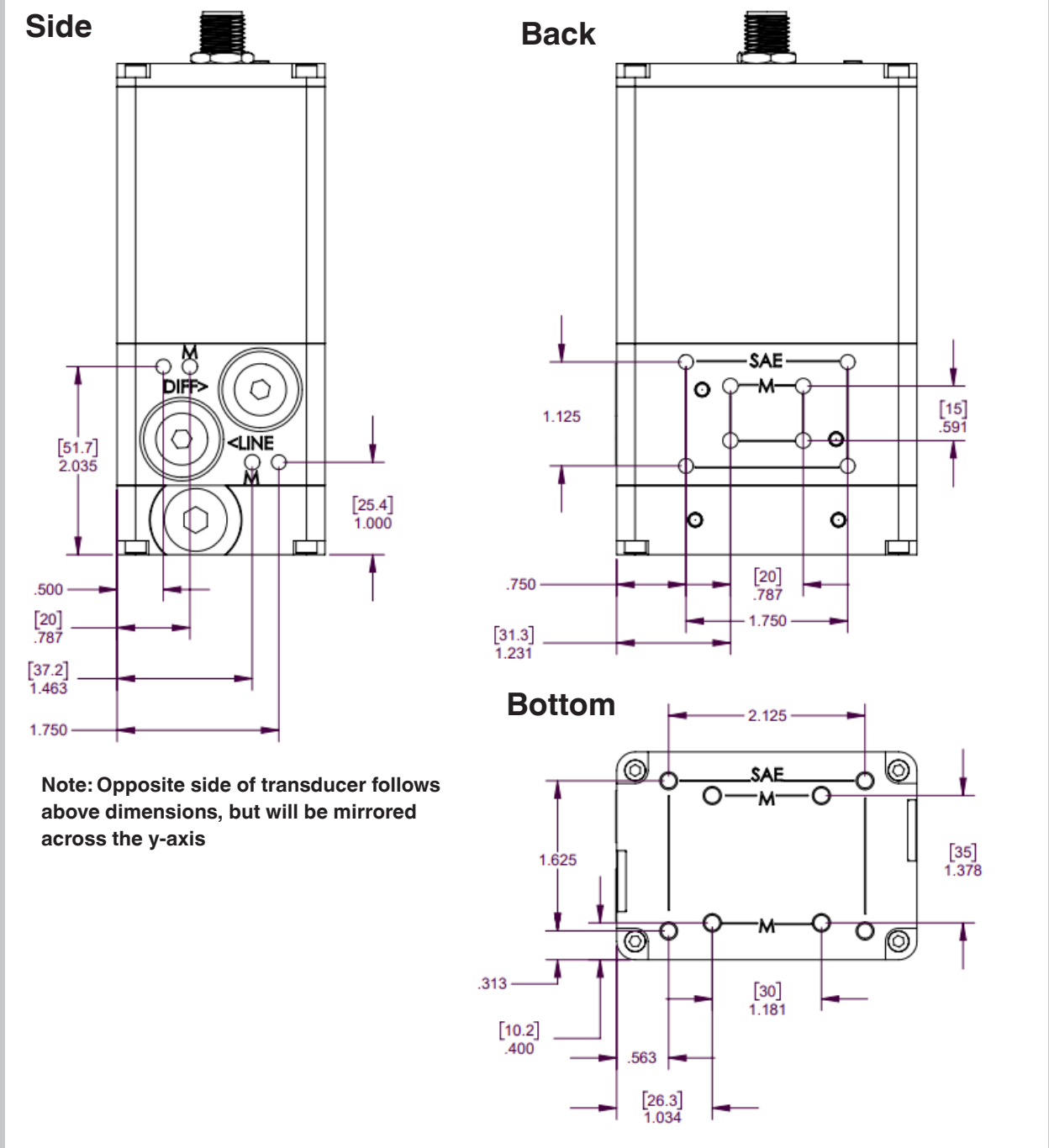

Figure 5.5B Mounting diagram with relief valve

0020962001A 09/2025 EN

Installation

5.6 Electrical Connections

5.6.1 RS-232/RS-485 Versions

Power supply should be 9 to 18 VDC (12 VDC nominal). The pinouts on the 9 pin D-Sub connector and RS-232 and RS-485 cable connections are:

External Connector Pinouts		
Pin	RS-232	RS-485
1		TX-
2	TX	RX+
3	RX	RX-
4		
5	Ground	Ground
6	+12VDC nominal	+12VDC nominal
7		
8		
9		TX+

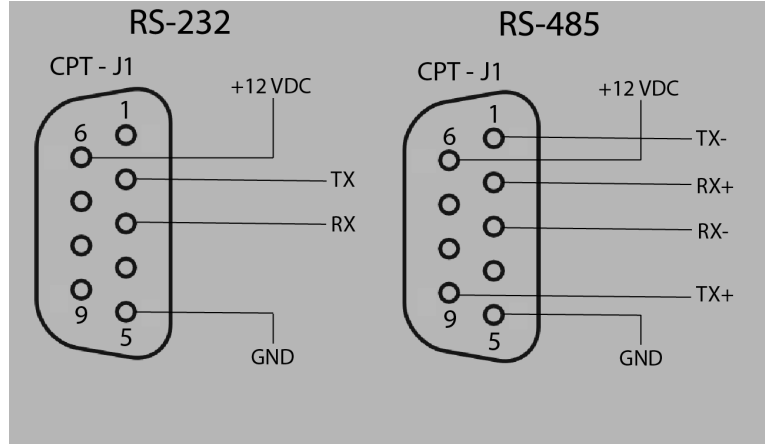

Figure 5.6.1 COM Connection Pin-out and RS-232 / RS-485 cable connections

5.6.2 USB Versions

USB version power supply is directly from host USB port. (3.0 to 5.25 VDC)

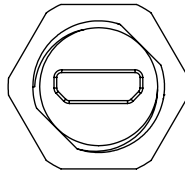

Figure 5.6.2A USB Connector

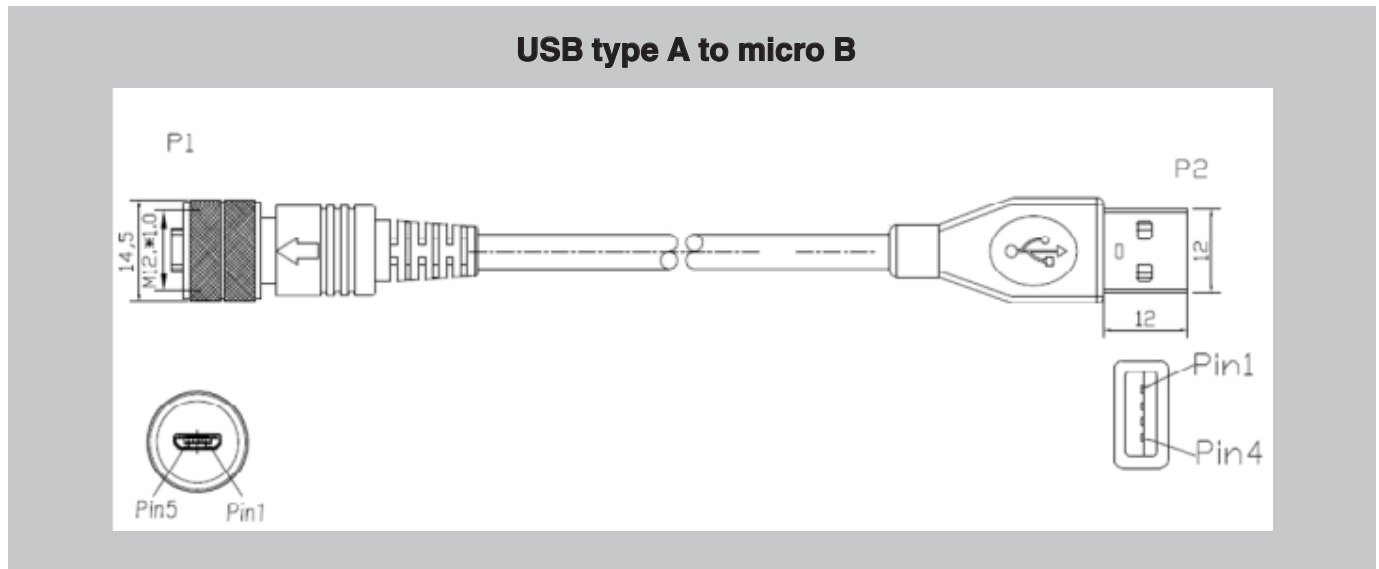

Figure 5.6.2B USB type A to micro B cable

6. Operation

6.1 General Operation

The CPT8900 transducer can be ordered with either a USB, RS-232, or RS-485 full duplex output. The communications protocol is defaulted to 57600,N,8,1. The baud rate can be configured at the time of order or it can be changed via remote commands. Connector pinouts, RS-232, RS 485, and USB cable connections are shown in Figure 5.6.1 and Figure 5.6.2A, respectively. The transducer has multiple command sets with which it can communicate with the host. These are set through the CMD_SET command.



Due to the nature of the various RS-485 converters available there may be communication issues. We have determined that our devices work with the ACCES I/O PRODUCTS devices. At this time we are not in a position to comment on any other make of RS-485 converters and their suitability for use with our products.

6.2 USB Driver

The CPT8900 with the USB interface uses a Silicon Labs CP210x family USB to UART bridge. Virtual COM Port drivers are required for the CPT8900 to be used as a virtual COM port. They can be downloaded from the Mensor website (Downloads>Software>Drivers), and from: <https://www.silabs.com/developers/usb-to-uart-bridge-vcp-drivers?tab=downloads>.

6.3 LED Colors

A small LED on top of the transducer will indicate the transducer's operating conditions, as shown in Table 6.3 below.

Color Indication	Condition
Blue	Transducer is saving data to permanent memory.
Green	Transducer is operating normally with no error conditions.
Red	Transducer has an error condition. To clear this, the error can be queried from the transducer and the condition cleared, then the errors can be cleared.

Table 6.3 - LED Color Indications

6.4 Command and Query Format

Commands must be sent in ASCII format and terminated with a carriage return (<CR>) optionally followed by a linefeed (<LF>). Commands are not case sensitive. Query strings are terminated with a "?" prior to the termination character(s). The host communications program must synchronize with the output of the transducer. The transducer's output to a pressure value query is programmable depending on what the user wants in the output string.

6.4.1 RS-485 Command and Query Format

On RS-485 versions of the CPT8900, the commands must be preceded by a "#", an address or a "★". In RS-485 the ADDRESS command sets the address in ranges from "0" to "9" and "A" to "Z". The global address character is the "★". When data is required for a command, a space (only) should delimit command and data fields.

6.4.2 RS-232 and USB Command and Query Format

On USB and RS-232 versions of the CPT8900, the "#" or address character is not necessary to precede the command with either command set.

6.4.3 Command Error Detection and Debugging

The CPT8900 has built in responses to correct and incorrect data. The responses can be used to help debug the software. In the Sensor command set, the device will return “Ready” in response to a valid data command.

Case	Return Value
Valid data command	“Ready”
Invalid data command	“Invalid Data”
Invalid command	“Unknown Command”
Query Customer password protected command	“User Password Needed”
Tried to query on settable only query	“Query Not Supported For This Command”
Tried to set parameter on non-settable query	“Set Not Supported For This Command”
Queried with sensor identifier, but it's only a global command	“Global Only Command”
Queried global command, but needs sensor identifier	“Individual Sensor Only Command”

Table 6.4.3 - Command set returns for given cases

Also, it is important to note that when sent data is determined to be valid, the value will be stored in RAM. Only after the SAVE command is sent is the data saved permanently. This applies to all command sets.

6.5 CPT8900 Commands and Queries

The following convention is used for the following command set tables:

Format	Description
n	1 placeholder for digits and decimal point
C	1 character placeholder for alpha character A-Z
<cr>	carriage return – ASCII 13
<lf>	line feed – ASCII 10
±	1 place holder for a + or – sign, or blank which implies +
<sp>	1 place holder for a space
X	address placeholder or ‘*’ for universal queries to be sent to all instruments
Y(1,2,3...)	strings as defined in description
<yy,mm,dd>	Last two digits of year, month, day

Table 6.5A - Format conventions

All commands, queries, and responses will be terminated with a <cr>. <lf> is optional.

Global Commands			
Query	Command	Data	Description
ADDRESS?	ADDRESS<sp><C>	C	Transducer address 0-9, A-Z
*IDN? (A/B)	N/A	Manu, Model, SN, SW Version	Manufacturer, Model, SN, SW Version.
ID? (A/B)	N/A	Manu, Model, SN, SW Version	Manufacturer, Model, SN, SW Version.
N/A	SAVE		Saves Data to EEPROM. Saves global EEPROM and both sensors.
BAUD?	BAUD<sp><n>	n	Baud Rate - 9600, 19200, 38400, 57600, 115200

N/A	CERR		Clears Error stack
N/A	DEFAULT		Defaults parameters per Section 6.5.4
CMD_SET?	CMD_SET<sp><n>	n	Selects command set 0/1 Sensor Set/Legacy Set
N/A	PWD_CHANGE<sp><n,n> (password protected)	nnnn,nnnn	Change password <n,n> = <old,new>
N/A	PWD<sp><n>	nnnn	Send Password
N/A	LOCK		Remove access to the password protected areas
UPDATE_RATE?	UPDATE_RATE<sp><n>	n	The frequency of continuous output mode (OUTPUT_MODE 2) in Hz. Valid range can be 2 Hz to 50 Hz (500 ms to 20 ms)
OUTPUT_MODE?	OUTPUT_MODE<sp><n>	n	Controls output mode: 0 - Query and response mode 1 - Continuous output at every conversion 2 - Continuous output at specified rate 3 - Burst Mode
OUTPUT_MASK?	OUTPUT_MASK<sp><n>	n	Configures output for “Press?” Query and Continuous Output– see Section 6.6.1
BURST_MASK?	BURST_MASK<sp><n>	n	Configures output for Burst Mode – see Section 6.6.4
BURST?	BURST<sp><n>	n	0 - Query mode 1 - Burst Mode (Sets OUTPUT_MODE to 3)
ERR?	N/A	n	Returns top error code on 18 deep LIFO stack. See Section 6.7
STATUS_LED?	STATUS_LED<sp><n>	n	Enable or disable the status LED 0 - OFF 1 - ON
N/A	RESET		Reset Sensor
Chan A Related (static)			
ALT?	N/A	+n.nnnnnnnE+nn	Altitude in current units
ALT_UNIT?	ALT_UNIT<sp><cc>	c	Altitude unit - ft, m
ALT_RATE?	N/A	+n.nnnnnnnE+nn	Altitude rate.
SEA_LEVEL?	CAL_SEA_LEVEL<sp><n> (password protected)	+n.nnnnnnnE+nn	Sea level adjustment in altitude units.
Chan B Related (differential)			
ROOT?	N/A	+n.nnnnnnnE+nn	Square root pressure output
I_AIRSPEED?	N/A	+n.nnnnnnnE+nn	Returns indicated airspeed in knots
T_AIRSPEED?	N/A		Returns true airspeed in knots
T_AIRSPEED_TEMP?	T_AIRSPEED_TEMP<n>	+n.nnnnnnnE+nn	Returns/sets air temperature for true airspeed in °C
Pressure Related Commands			
FILTER? (A/B)	FILTER<sp><n>	n	Filter percentage 1 to 99 Setting global filter sets both transducers
WINDOW? (A/B)	WINDOW<sp><nn>	n	Pressure filter window as % FS 0 to 99 Setting global window sets both transducers

0020962001A_09/2025 EN

PRESS? (A/B)	N/A		Global - returns differential pressure (Ch. B) in current units Ch. Specific – returns channel pressure in current units
PRESS_RAW? (A/B)	N/A		Global - returns differential pressure (Ch. B) in psi Ch. Specific - returns channel pressure in psi
? (A/B)	N/A		Global - returns differential pressure (Ch. B) Ch. Specific – returns channel pressure
RATE_MODE?	RATE_MODE<sp><n>	n	0 - Instantaneous rate 1 - True history rate calculation
RATE_BASE?	RATE_BASE<sp><cc>	c	Rate denominator - S,M,H,3H
RANGE_MIN.X? (A/B O)	N/A	+n.nnnnnnnE+nn	Minimum range in current units.
RANGE_MAX.X? (A/B O)	N/A	+n.nnnnnnnE+nn	Maximum range in current units
PRESS_LIM_MIN.X? (A/B O)	PRESS_LIM_MIN.X<sp><n>	+n.nnnnnnnE+nn	Low alarm limit in current units.
PRESS_LIM_MAX.X? (A/B O)	PRESS_LIM_MAX.X<sp><n>	+n.nnnnnnnE+nn	High alarm limit in current units.
UNIT_INDEX.X? (A/B O)	UNIT_INDEX.X<sp><n>	n	Mensor unit index: 1-39 or 99 for CUST_UNIT. See Section 6.5.3
UNIT.X? (A/B O)	N/A	ccccccccc	Unit text 10 char - mmHg, psi, kPa...
ACCURACY.X? (A/B O)	N/A	ccccccccc	Returns Accuracy string
CUST_UNIT?	CUST_UNIT<sp><n>	+n.nnnnnnnE+nn	Sets custom unit multiplication (xx/psi)
Calibration Related Commands			
CAL_DATE.X? (A/B O)	CAL_DATE.X<sp><yy,mm,dd> (password protected)	nn,nn,nn	Calibration date
IS.X? (A/B O)	N/A	n	Intelliscale flag y/n - 1/0
SPAN.X? (A/B O)	CAL_SPAN.X<sp><n> (password protected)	+n.nnnnnnnE+nn	Customer span multiplier - 0.99 to 1.01
ZERO.X? (A/B O)	CAL_ZERO.X<sp><n> (password protected)	+n.nnnnnnnE+nn	Customer zero adder
INTERVAL.X? (A/B O)	CAL_INTERVAL.X<sp><n> (password protected)	n	Calibration interval in days
TARE?	TARE<sp><n>	n	Turns differential tare pressure on/off - 1/0
TARE_OFFSET?	N/A	+n.nnnnnnnE+nn	Gets the offset if Tare is set to 1
Temperature Related Commands			
TEMP? (A/B)	N/A	+nnn.n	Temperature in deg. C.
TEMP_LIM_MIN? (A/B)	TEMP_LIM_MIN(.X)<sp><n>	+n.nnnnnnnE+nn	Temperature low alarm limit
TEMP_LIM_MAX? (A/B)	TEMP_LIM_MAX(.X)<sp><n>	+n.nnnnnnnE+nn	Temperature high alarm limit

Linearity Related Commands			
LIN_COEFF.X? (A/B O)	CAL_LIN_COEFF.X<sp><n,n> (password protected)	+n.nnnnnnnE+nn	Customer linearity coefficients
LIN_SEGS.X? (A/B O)	CAL_LIN_SEGS.X<sp><n> (password protected)	n	Linearity correction segments 0 to 10
Channel Specific Uncertainty Related Command			
UNC? (A/B)	N/A	+n.nnnnnnnE+nn	Measurement uncertainty in current units

Table 6.5B – Sensor Command Set

6.5.1 Command Structure Topology

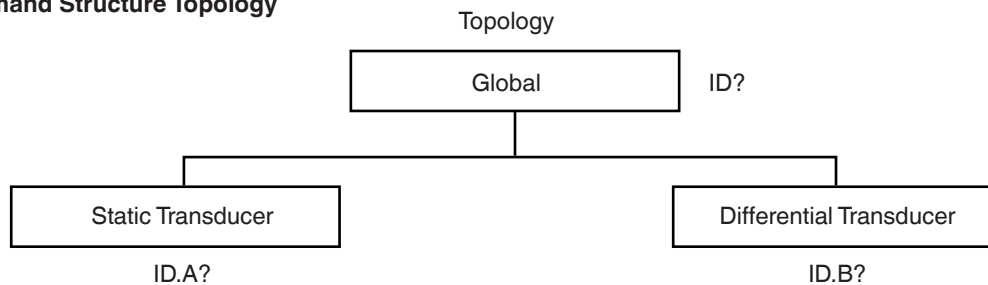

Below is a table giving specific examples on how to use the above topology:

Command Structure		
Scenario	Interface	String to send
Query Global ID String	RS-232	ID?
	USB	ID?
	RS-485	#*ID?
Query Channel A ID String	RS-232	ID.A?
	USB	ID.A?
	RS-485	#*ID.A?

Global commands that are pressure specific, operate on the differential channel.

(A/B) indicates that the command/query works at a global and a channel level by appending .A for the static sensor or .B for the differential sensor. An example is shown below:

- ID? Returns Manufacturer, Model, SN, SW Version for the overall instrument.
- ID.A? Returns Manufacturer, Model, SN, SW Version for the static sensor.
- ID.B? Returns Manufacturer, Model, SN, SW Version for the differential sensor.

(A/B O) indicates that the command/query works only at a channel level by appending .A or .B for the static and differential sensors, respectively.

6.5.2 Password Protection

In the Sensor Command Set, data that affects calibration is protected by a user settable 4 character password (designated as “Password Protected”). The default password is “0000”. This is changed using the PWD_CHANGE command. It should be changed once the user receives the device. The factory password will override the user’s password in the case that the user loses their password. All commands that are password protected are designated with “(password protected)” in the Command column.

0020962001A_09/2025 EN

6.5.3 Units

The CPT8900 has 39 built in units available to use for pressure outputs, including an option to define a new unit. The 39 available units, their unit indexes, and scaling factors are represented below:

Unit Index	Abbreviation	Scaling Factor from PSI	Unit Index	Abbreviation	Scaling Factor from PSI
1	psi	1	21	Torr	51.71508
2	inHg 0C	2.03602	22	kPa	6.894757
3	inHg 60F	2.041772	23	Pa	6894.757
4	inH2O 4C	27.68067	24	dy/cm2	68947.57
5	inH2O 20C	27.72977	25	g/cm2	70.30697
6	inH2O 60F	27.70759	26	kg/cm2	0.07030697
7	ftH2O 4C	2.306726	27	MSW 0C	0.6838528
8	ftH2O 20C	2.310814	28	osi	16
9	ftH2O 60F	2.308966	29	psf	44
10	mTorr	51715.08	30	tsf	0.072
11	inSW 0C	26.92334	31	Not used	
12	ftSW 0C	2.243611	32	uHg 0C	51715.08
13	atm	0.06804596	33	tsi	0.0005
14	bar	0.06894757	34	mHg 0C	0.05171508
15	mbar	68.94757	35	hPa	68.94757
16	mmH2O 4C	703.089	36	MPa	0.00689476
17	cmH2O 4C	70.3089	37	mmH2O 20C	704.336
18	mH2O 4C	0.703089	38	cmH2O 20C	70.4336
19	mmHg 0C	51.71508	39	mH2O 20C	0.704336
20	cmHg 0C	5.171508	99	CUST_UNIT	CUST_UNIT

Table 6.5.3 - Units

6.5.4 Default Command

Settings for Customer "DEFAULT" Command

Parameter	Setting
Filter	90
Window	10
Baud	57600
Error Queue	Erased
CMD_SET	0
PRESS_LIM_MIN	Minimum Range - 5%FS (or 0, if 0 based)
PRESS_LIM_MAX	Maximum Range + 5%FS
CUST_UNIT	1
OUTPUT_MASK	0
OUTPUT_MODE	0

Parameter	Setting
UPDATE_RATE	20
BURST_MASK	0
RATE_ON	1
RATE_MODE	1

Table 6.5.4 - Default Settings

6.6 Transducer Outputs

There are four modes in which the transducer can output data. This is set by the “OUTPUT_MODE” parameter. If the output mode is set to 0, the transducer will only output data when queried. In output mode 1, the transducer will continually output readings as soon as a conversion cycle is completed. In output mode 2, the device will continually output data at a rate that is specified by the “UPDATE_RATE” command. This is useful because some users may want to collect every pressure data point. Output mode 1 guarantees every pressure calculation is output. When the output mode is set to 3, burst mode is selected. When the device is in burst mode, a continuous streaming output in IEEE 754 Format will occur. Output modes 1, 2, and 3 are streaming outputs, but differ in how they stream. The modes of operation are summarized below:

MODE	OUTPUT MODE	DESCRIPTION
Query Mode	0	Device only outputs when queried
Continuous Mode after pressure calculation	1	Device outputs after each calculation cycle
Continuous Mode at fixed time interval	2	Device outputs at update rate value set by UPDATE_RATE
Burst Mode	3	Device uses streaming output, but in IEEE754 Format

Table 6.6 - Transducer Outputs

6.6.1 Output Mode 0 - Query Mode

The “PRESS?” query returns a programmable ASCII string based on the selections set by the “OUTPUT_MASK” variable. The selected parameters will populate the output string with commas separating the variables in the order in which they appear in the following table:

Individual Channel Output Mask				
Parameter	Description	Weight	Format	Max Length in characters (plus 1 comma between fields)
Pressure	Pressure in current units	Fixed	+n.nnnnnnnE+nn	14
Units	Unit Description	1	CCCCCCCC	10
Rate	Pressure rate in current units/time base	2	+n.nnnnnnnE+nn	14
Uncertainty	Measurement uncertainty in current units	4	+n.nnnnnnnE+nn	14
Temperature	Sensor temperature in current temp units	8	+nn.n	6
Stable	0/1 - unstable/stable	16	n	1
Error	0/1 - no errors/error(s) in stack	32	n	1
Checksum	Checksum of output string	64	n	2
Address	Adds RS-485, addresses responses	128	n,<sp>	2

Table 6.6.1A - Individual Sensor Mask Description

0020962001A 09/2025 EN

Global Output Mask				
Parameter	Description	Weight	Format	Max Length in characters (plus 1 comma between fields)
Differential Pressure	Differential pressure in current units	Fixed	+n.nnnnnnnE+nn	14
Differential Rate	Differential pressure rate in current units/time base	1	+n.nnnnnnnE+nn	14
Static Pressure	Static pressure in current units	2	+n.nnnnnnnE+nn	14
Static Rate	Static pressure rate in current units/time base	4	+n.nnnnnnnE+nn	14
Units	Differential unit description	8	CCCCCCCC	10
Uncertainty	Differential measurement uncertainty in current units	16	+n.nnnnnnnE+nn	14
Temperature	Differential sensor temperature in current temperature units	32	+nnn.n	6
Stable	0/1 – unstable/stable	64	n	1
Error	0/1 – no errors, error(s) in stack	128	n	1
Checksum	Checksum of output string	256	n	2
Address	Adds RS-485 address to the beginning of the responses	512	n,<sp>	2

Table 6.6.1B - Query Mode Mask Description

Example #1 of OUTPUT_MASK:

User wants the following parameters appended to their differential pressure reading: units, error flag, and checksum. The OUTPUT_MASK for this configuration would be 1+8+256 = 265. These numbers come from the 'Weight' column of Table 6.6.1, for the corresponding parameters.

```
>>OUTPUT_MASK 265
<<READY
>>PRESS?
<<+1.8330656E-03, psi,0,ae
```

Example #2 of OUTPUT_MASK:

When the address bit (value 512) is turned on, the address will precede any response from the transducer. This is important for RS-485, because the user will want addressed responses. The address response will include the 1-character address, 1 comma, 1 space, and then the normal data.

User wants address, differential pressure, and static pressure. OUTPUT_MASK = 1+2+512 = 514

```
>>OUTPUT_MASK 514
>>READY
>>PRESS?
<< 1, +1.7634571E-03,+1.4634571E+01
```

6.6.2 Output Mode 1 - Continuous Mode after Pressure Calculation

In output mode 1, the device will output the same ASCII based string that Table 2.8 describes. The device will output the ASCII based string after each pressure calculation cycle is completed. In output mode 1, the speed of the pressure output is dependent on the conversion rate of the A/D. The baud rate must be 57600 or higher.

6.6.3 Output Mode 2 - Continuous Mode at Specified Time Interval

This mode will output pressure outputs at a specified time interval (UPDATE_RATE). The update rate is entered in Hertz. The update rate can be as fast as 100 Hz (10 ms), and as slow as 2 Hz (500 ms). If a user requests a frequency faster than 100 Hz, then consult with engineering about increasing the speed. The baud rate must be 57600 or higher for this mode to work properly.

6.6.4 Output Mode 3 - Burst Mode

The transducer has the ability to continually output a limited set of binary data based on the selections set by the “BURST_MASK” variable. The selected parameters will populate the output string with no delimiters in the order in which they appear in the following table:

Parameter	Description	Weight	Format	Length in bytes (plus 1 comma between fields)
Differential Pressure	Differential pressure in current units	Fixed	IEEE 754	8
Differential Rate	Differential pressure rate in current units/time base	1	IEEE 754	8
Static Pressure	Static pressure in current units	2	IEEE 754	8
Static Rate	Static pressure rate in current units/time base	4	IEEE 754	8
Uncertainty	Measurement uncertainty in current units – IEEE754	8	IEEE 754	8
Temperature	Sensor temperature in current temp units	16	IEEE 754	8
Stable	0/1 – unstable/stable	32	n	1
Error	0/1 – no errors, error(s) in stack	64	n	1
Checksum	Checksum of output string	128	n	2

Table 6.6.4 - Burst Mode Mask Description

6.6.5 Rate Calculation

The differential and static rate outputs are determined using the “RATE_BASE” variable. This command can be set to change per 1 second, 1 minute, 1 hour, or 3 hours. The device will then calculate the pressure rate of change from the current pressure calculation to the last calculation and linearize the rate over the specified rate base.

The rate calculation also has a “RATE MODE” option. There are two rate modes. RATE_MODE 0 calculates the “instantaneous” rate. This is done by calculating the best fit line slope of the past 5 points. Then, scales the slope to time base specified by RATE_BASE. RATE_MODE 1 calculates the true history rate for the set rate base (see Table 6.6.5). This is done by collecting data for a given amount of time (s, m, h, 3h), and finding the slope of the given data. Because of finite memory, the microcontroller averages readings to create a reduced model of the pressure over time. For a base of a second, the readings are averaged every 100 ms. For a base of a minute, the readings are averaged every 1 s. For a base of hour and 3 hour, the readings are averaged every minute.

RATE_BASE	History Array	Minimum Points for Accurate Rate Output	Charge Period
S	100-ms PAVG's	10	1 second
M	1-s PAVG's	60	1 minute
H	1-m PAVG's	60	1 hour
3H	1-m PAVG's	180	3 hours

Table 6.6.5 - Summary of True History Rate Mode (RATE_MODE 1)

The advantage of the instantaneous rate mode is that the output reflects on the change in pressure at the current moment, much like a speedometer on a car. The disadvantage is that the output for the large time bases may be misleading.

The advantage of the true history mode is that the output truly reflects the change in pressure over the set rate base. The disadvantage is that it requires a charge period.

0020962001A_09/2025 EN

6.6.6 Checksum Calculation

The checksum is calculated by adding all the characters of the output string, including the comma delimiters. The checksum does not include carriage return or line feed. The checksum is stored in a 1 byte, 2 digit hexadecimal integer; therefore will roll over and only keep the remainder. This is true for all output modes. The hexadecimal number does not include a "0x" prefix.

6.7 Error Codes

The CPT8900 has a feature to alert the user of errors that have occurred. In the Sensor command set, the command "ERR?" can be used to query the microcontroller for errors that have occurred. Error codes are stored in a LIFO stack and returned in reverse order in which they occurred. Eleven errors can be stored before the internal stack is full. If no error has occurred, then the query will return "NO ERROR". The following table represents the possible errors and their causes.

Error	Descriptions
NO ERROR	No error has occurred since last power up.
LOADED MENSOR DEFAULTS	EEPROM was empty so Factory Defaults were loaded.
WATCHDOG TIMEOUT	Watchdog timeout has occurred.
UART BUFFER OVERFLOW	The UART buffer received more than 512 bytes of data.
ERROR QUEUE IS FULL	The error queue is now full. This is the last error to fill the stack.
CAL ERROR. CONTACT FACTORY	RTCC drift days is greater than 10000 or less than 0.
SENSOR 1 OVERPRESSURED	The calculated pressure was greater than the value stored in PRESS_LIM_MAX.A.
SENSOR 1 UNDERPRESSURED	The calculated pressure was less than the value stored in PRESS_LIM_MIN.A.
SENSOR 1 OVERTEMPERATURE	The calculated temperature was greater than the value stored in TEMP_LIM_MAX.A.
SENSOR 1 UNDERTEMPERATURE	The calculated temperature was less than the value stored in TEMP_LIM_MIN.A.
SENSOR 2 OVERPRESSURED	The calculated pressure was greater than the value stored in PRESS_LIM_MAX.B.
SENSOR 2 UNDERPRESSURED	The calculated pressure was less than the value stored in PRESS_LIM_MIN.B.
SENSOR 2 OVERTEMPERATURE	The calculated temperature was greater than the value stored in TEMP_LIM_MAX.B.
SENSOR 2 UNDERTEMPERATURE	The calculated temperature was less than the value stored in TEMP_LIM_MIN.B.
SENSOR 1 EXCEEDED CALIBRATION INTERVAL	Sensor.A has exceeded CAL_INTERVAL.A
SENSOR 2 EXCEEDED CALIBRATION INTERVAL	Sensor.B has exceeded CAL_INTERVAL.B

Table 6.7 - Possible Errors and Causes

The error queue can be cleared in three different ways. The first is to send "ERR?" repeatedly until "NO ERROR" is returned unless there is a continuous error. The second way to clear the queue is to send the "CERR" command, which clears the queue immediately. The third and last way is to simply cycle the power of the transducer. The error queue is stored in volatile memory, therefore is cleared on power down.

7. Maintenance and Recalibration



For contact details, please see Chapter 1 “General information” or the back page of the operating instructions.

7.1 Maintenance

The CPT8900 was designed for maintenance-free operation. User maintenance is not recommended. If you have questions not covered by this manual, call 1-800-984-4200 (USA only), or 1-512-396-4200 for assistance, or send an email to techservices@mentor.com.

7.1.1 Beyond the Warranty

Take advantage of Mensor’s expert product care. Mensor provides complete maintenance and calibration services, available for a nominal fee. Our service staff is knowledgeable in the innermost details of all of our transducers. We maintain units that are in operation in many different industries and in a variety of applications, and by users with a wide range of requirements. Returning your transducer to Mensor for service benefits you in several ways:

- Our extensive knowledge of the transducer assures you that it will receive expert care.
- Repair or replacement of the CPT8900 transducers will be available up to 7 years after the production life cycle of the product, pending external vendor parts or equivalent parts availability. The production life cycle is defined as the time from the product series launch to the announcement of discontinuation (typically 8 to 10 years).
- All repairs should be performed by Mensor due to the complexity of performing these repairs.

7.2 Recalibration

The CPT8900 automatically calculates the pressure reading for all effects of temperature, hysteresis, repeatability and non-linearity within the compensated temperature range. The process is referred to as dynamic compensation because each reading is adjusted before it is output. Thus, a calibrated CPT8900 operated within its temperature band, and with proper zero and span adjustments, will provide accurate pressure measurements.

The CPT8900 should have the calibration verified periodically to ensure stability. The recommended calibration interval for this instrument is given in the Specifications section under “Calibration Interval” in Section 9.1.

7.2.1 Calibration Services by Mensor or WIKA worldwide

Mensor and WIKA worldwide have extensive experience and knowledge of Mensor products. Calibration of the transducers can be performed at the addresses below or by competent internal or external labs using the procedures in this section.

Service Center USA	Service Center Europe
Mensor website: www.mentor.com tel: 1-512-396-4200 1-800-984-4200 fax: 1-512-396-1820 email: tech.support@mentor.com	WIKA Alexander Wiegand SE & Co. KG website: www.wika.de / www.wika.com tel: (+49) 9372 132-0 fax: (+49) 9372 132-406 email: CTSERVICEteam@wika.com
Service Center China	WIKA Instrumentation PTE. LTD.
WIKA China website: www.wika.cn contact: Eric Wang tel: (+86) 512 6878 8000 fax: (+86) 512 6809 2321 email: eric.wang2@wika.com	13 Kian Teck Crescent 628878 Singapore Tel: +65 6844 5506 E-mail: info@wika.sg

7.2.2 Environment

For maximum accuracy, allow the CPT8900 to warm up a minimum of 15 minutes in ambient temperature within the compensated range prior to a calibration. In addition, the instrument should be at rest on a stable platform that is free of excessive vibration, shock and with minimal temperature change.

7.2.3 Pressure Standards

Mensor recommends the use of appropriately accurate primary pressure standards when calibrating this instrument. Such standards should be sufficient so that when the techniques of the ISO Guide to the Expression of Uncertainty in Measurement (GUM) are applied, the instrument meets its accuracy statements as required by ISO/IEC 17025:2005, or other applicable standards.

7.2.4 Media

The recommended calibration medium is dry nitrogen or clean dry instrument air. A reference height variation between the standard and the CPT8900 can cause errors. A calculation should be made to compensate for this difference.

7.2.5 Setup

The CPT8900 has common pressure ports on both ends of the transducer. It comes with two plugs on one end that can be removed or replaced on the opposite end of the transducer for installation convenience. Note that they are in different orientations on the two ends.

7.2.5.1 Differential Sensor Calibration Setup

If a single reference pressure source is to be used, just connect it to the differential pressure port. Optionally, if multiple sources are to be used, connect the static pressure source to the static port, and the source providing the differential pressure to the differential port. If multiple sources are used, care must be taken to avoid overpressuring the differential sensor. See Figure 7.2.5.1 for an example setup.

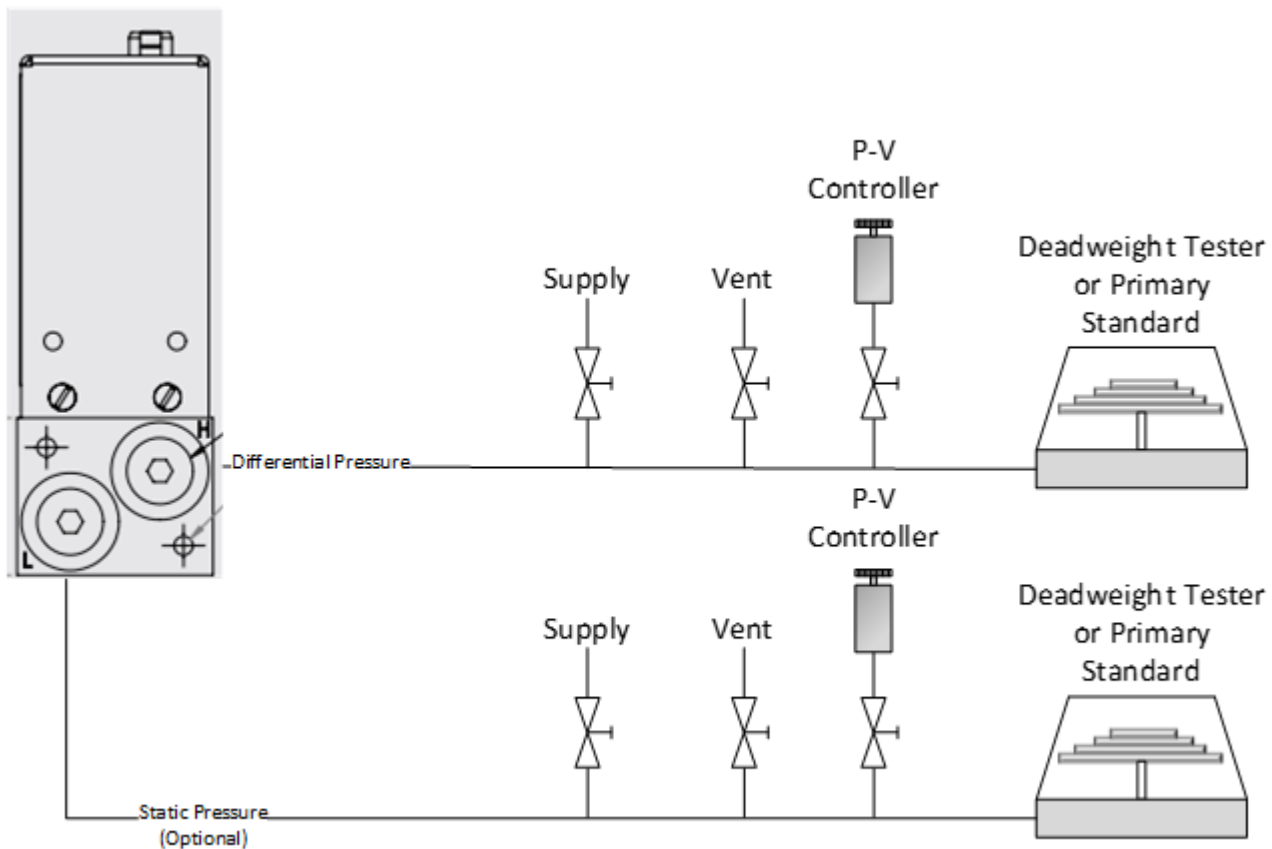

Figure 7.2.5.1 - Example Differential Sensor Calibration Setup

7.2.5.2 Static Sensor Calibration Setup

Internally, the static pressure sensor is pneumatically connected to the reference of the differential sensor. If the pressure range of the static sensor is >15 psia (1 bar a), the differential and static ports **MUST** be pneumatically tied together externally to the transducer. The best practice is to simply tie them together anytime you are calibrating the static sensor. Mensor offers a calibration adapter to aid in this requirement. See Figure 7.2.5.2 for an example setup.

When calibrating the static sensor and approaching very low absolute pressures, a needle valve or controlled leak must be used to maintain a small pressure (600 mTorr, 80 Pa recommended) throughout the system. If calibration points are run below that pressure, the system will have significant pressure gradients in it unless left to stabilize for an extended period of time.

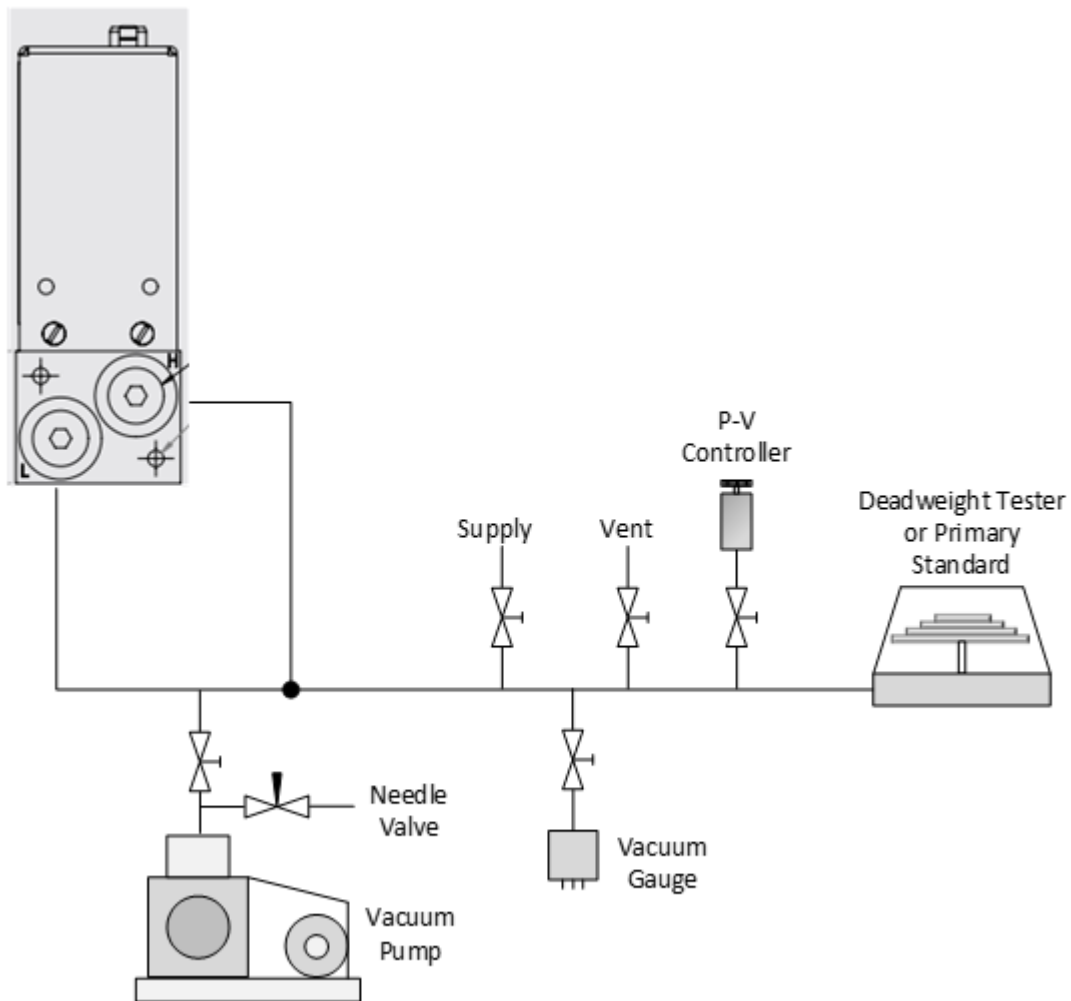

Figure 7.2.5.2 - Example Static Sensor Calibration Setup

7.2.6 Calibration & Communication Software

The Operation and Calibration software utility is available on the Mensor.com website from the main menu select **Service/Calibration** then **Download Software** then **PC Software**.

EN

The purpose of this software is to communicate with the CPT8900 transducer. Calibration of the transducer output and configuration of various parameters can be accomplished. It has many features that allow you to read and adjust the rich feature set including:

- Changing filter settings
- Modifying custom identification strings
- Showing the CPT8900's error stack
- Setting the tare pressure on the CPT8900
- Modifying the output format of the sensor
- Changing the pressure units output

It also has many features to adjust various calibration parameters after the appropriate password is sent:

- Setting the calibration date
- Setting the calibration interval
- Setting custom pressure units
- Setting sea level adjustment on barometric range transducers
- Setting minimum and maximum pressure alarm limits
- Setting minimum and maximum temperature alarm limits
- Setting Zero and Span
- Adjusting the CPT8900 linearity
- Resetting the calibration password
- Restoring the factory calibration

8. Dismounting, Return and Disposal

**WARNING!****Physical injuries and damage to property and the environment through residual media**

Residual media in the dismantled instrument can result in a risk to persons, the environment and equipment.

- ▶ Wear the requisite protective equipment (see Chapter 3.6 “Personal protective equipment”).
- ▶ Observe the information in the material safety data sheet for the corresponding medium.
- ▶ Wash or clean the dismantled instrument, in order to protect persons and the environment from exposure to residual media.

8.1 Dismounting

**WARNING!****Physical injuries and damage to property and the environment through residual media**

Upon contact with hazardous media (e.g. oxygen, acetylene, flammable or toxic substances), harmful media (e.g. corrosive, toxic, carcinogenic, radioactive), and also with refrigeration plants and compressors, there is a danger of physical injuries and damage to property and the environment.

- ▶ Before storage of the dismantled instrument (following use) wash or clean it, in order to protect persons and the environment from exposure to residual media.
- ▶ Wear the requisite protective equipment (see Chapter 3.6 “Personal protective equipment”).
- ▶ Observe the information in the material safety data sheet for the corresponding medium.

**WARNING!****Risk of burns**

During dismantling there is a risk of dangerously hot media escaping.

- ▶ Let the instrument cool down sufficiently before dismantling it!

**WARNING!**

Power should be switched off before disconnecting the device.

**WARNING!****Physical injury**

When dismantling, there is a danger from aggressive media and high pressures.

- ▶ Wear the requisite protective equipment (see Chapter 3.6 “Personal protective equipment”).
- ▶ Observe the information in the material safety data sheet for the corresponding medium.
- ▶ Only disconnect the pressure measuring instrument/measuring assembly/test and calibration installations once the system has been depressurised.

8.2 Return

Strictly observe the following when shipping the instrument:

All instruments delivered to WIKA or Mensor must be free from any kind of hazardous substances (acids, bases, solutions, etc.) and must be cleaned before being returned.

EN



WARNING!

Physical injuries and damage to property and the environment through residual media

Residual media in the dismantled instrument can result in a risk to persons, the environment and equipment.

- ▶ With hazardous substances, include the material safety data sheet for the corresponding medium.

When returning the instrument, use the original packaging or a suitable transport packaging.

To avoid damage:

1. Wrap the instrument in an anti-static plastic film.
2. Place the instrument along with shock-absorbent material in the packaging.
Place shock-absorbent material evenly on all sides of the transport packaging.
3. If possible, place a bag containing a desiccant inside the packaging.
4. Label the shipment as a highly sensitive measuring instrument.

Instruments with lithium ion rechargeable batteries or lithium metal batteries

The included lithium ion rechargeable batteries or lithium metal batteries are subject to the requirements of the dangerous Goods Act. For shipping, special packaging and labelling requirements must be observed. A dangerous goods expert must be consulted when preparing the item to be shipped. Do not send any damaged or defective rechargeable batteries. Cover open contacts with adhesive tape and package the rechargeable battery such that it cannot move inside the package and short circuits are prevented. The different requirements of the relevant transport carriers as regard to the Dangerous Goods Act and also additional national regulations must be observed.



Information on returns can be found under the heading "Service" on our local website.

8.3 Disposal

Incorrect disposal can put the environment at risk.

Dispose of instrument components and packaging materials in an environmentally compatible way and in accordance with the country-specific waste disposal regulations.



This marking on the instruments indicates that they must not be disposed of in domestic waste. The disposal is carried out by return to the manufacturer or by the corresponding municipal authorities.

9. Specifications

Accuracy specifications presented herein are obtained by comparison with primary standards traceable to a national metrology institute or recognized international standard organization. These specifications are obtained in accordance with the ISO Guide to the Expression of Uncertainty in Measurement (GUM). The calibration program at Mensor is accredited by the American Association of Laboratory Accreditation (A2LA) as complying with both the ISO/IEC 17025:2005 and the ANSI/NCSL Z540-1-1994 standards. If there is an exception to the requirements and recommendations of Z540 during a calibration the exception is noted on the individual calibration certificate.

Mensor reserves the right to change specifications without notice.

9.1 Measurement Specification

Precision Pressure Transducer		
Static Line		
Range	0 ... 5 to 0 ... 250 psia (0 ... 350 mbar to 0 ... 17 bar)	
Accuracy ¹⁾	0.01% FS (standard)	
	0.008% FS (optional)	
	0.008% IS-50 ²⁾ (optional)	For ranges >15 psi (1 bar) only
	0.008% IS-33 ³⁾ (optional)	
Differential		
Range	±0.18 to -15 ... 1500 psi d (±12.5 mbar to -1 ... 100 bar d)	
Accuracy	0.01% FS or 0.03% FS, depending on range (see table below)	
Calibration interval	365 days	
Pressure units	39 and 1 user defined	
<p>1) It is defined by the total measurement uncertainty, with the coverage factor (k = 2) and includes the intrinsic performance of the instrument, the measurement uncertainty of the reference instrument, long-term stability, influence of ambient conditions, drift, and temperature effects over the compensated range with recommended zero point adjustment every 30 days.</p> <p>2) 0.008 % IS-50 accuracy: Between 0 ... 50 % of the full scale, the accuracy is 0.008% of half of the full scale value and between 50 ... 100 % of the full scale, the accuracy is 0.008 % of reading.</p> <p>3) 0.008 % IS-33 accuracy: Between 0 ... 33 % of the full scale, the accuracy is 0.008% of one third of the full scale value and between 33 ... 100 % of the full scale, the accuracy is 0.008 % of reading.</p>		

Precision Differential Pressure Sensor Technology	
Range ⁴⁾	Accuracy ⁵⁾
±0.18 to -3 ... 3 psi d (±12.5 mbar to -200 ... 200 mbar d)	0.03% FS ⁶⁾
-15 ... 1500 psi d (-1 ... 100 bar d)	0.01% FS ⁷⁾
<p>4) The negative portion of a bidirectional range has the same accuracy as the equivalent positive range.</p> <p>5) It is defined by the total measurement uncertainty, with the coverage factor (k = 2) and includes the intrinsic performance of the instrument, the measurement uncertainty of the reference instrument, long-term stability, influence of ambient conditions, drift, static line pressure effects over the full static range, and temperature effects over the compensated range with recommended zero point adjustment every 30 days.</p> <p>6) Maximum static range available for this differential range is 0 ... 120 psia (0 ... 8.25 bar).</p> <p>7) For 0.01% FS accuracy, the differential range must have a span ≥20 psi (1.4 bar). For ranges with a span <20 psi (1.4 bar), the accuracy will be 0.03% FS.</p>	

Approvals and Certificates		
Logo	Description	
	EU Declaration of Conformity EU Importer: WIKA, 63911 Klingenberg, Germany	European Union
Certificates		
Calibration	Standard: A2LA accredited calibration certificate (standard on factory)	
Recommended recalibration interval	365 days	

0020962001A_09/2025 EN

Specifications

9.2 General Specification

General Specifications ⁸⁾

Case

Orientation effects	Removable with re-zeroing
Dimensions	See technical drawings
Weight	< 2.2 lbs (< 1 kg) (without dual differential relief valve)
Ingress protection	IP-20

Display

Resolution	100 ppb or better
Boot-up time	<2 sec.
Warm-up time	15 min.

Connections

Pressure Ports	7/16-20 SAE (female)
Overpressure limit	2X proof, 3X burst
Pressure port adapters	Standard: without Optional: 6mm tube fitting, 1/4" tube fitting, 1/4" NPT female fitting, 1/8" NPT female fitting, 1/8" BSPG female fitting
Materials, wetted parts	316L SS, 6061 T6 aluminum, brass < 5 psi: silicon, epoxy, glass-filled resins
Pressure media	Clean, dry, non-corrosive gases

Voltage supply

Power supply	RS-232/RS-485: 9 to 18 VDC (12 VDC nominal) USB: 3.0 to 5.25 VDC (5VDC nominal) Bus Powered
Power consumption	RS-232/485: <48 mA at 12 VDC ±5% (0.57 Wmax) USB: <44mA at 5 VDC ±5% (0.22 Wmax)

Permissible ambient conditions

Compensated temperature range	0 to 50 °C (32 to 122 °F)
Operating temperature range ⁹⁾	-40 to 85 °C (-40 to 185 °F)
Storage temperature range	-40 to 85 °C (-40 to 185 °F)
Humidity	0 ... 95% r.h. (non-condensing)
Operating altitude	<2000 meters (6,500 feet)
Place of use	Indoor Not for wet locations
Pollution degree	Degree 2

Internal volume

Differential port	without relief valve: 3.6 cc	with relief valve: 6.4 cc
Static (reference) port	without relief valve: 3.6 cc	with relief valve: 6.6 cc

Communication

Interface	USB 2.0, RS-232 or RS-485
Baud rate	Default 57,600 baud - 9600, 19200, 38400 and 115200 user selectable
Measuring rate	50 values/second, default (standard)
Command sets	See manual, Section 6 Operation

⁸⁾ Some specifications may be adjusted at the factory to fit unique applications. Please contact Mensor to discuss your requirements.

⁹⁾ The standard power adapter included with the CPT8900 (RS-232/RS-485) is rated for operation only between 0 °C and 40 °C. If operation is required outside this range, the user must use a qualified external DC power supply rated for the intended environmental conditions of the transducer (-40°C to 85°C).

Specifications

9.3 Dimensions in in [mm]

Front Profile

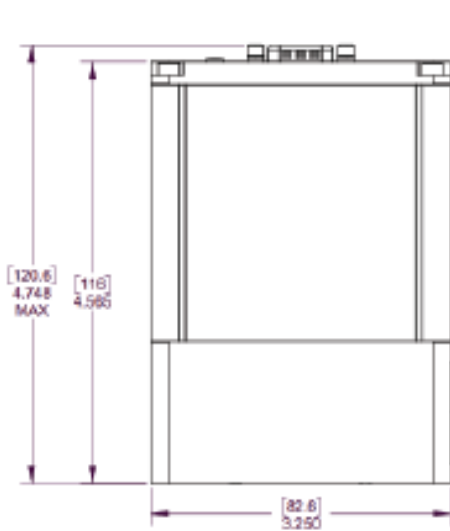

RS-232/RS-485
No Relief Valve

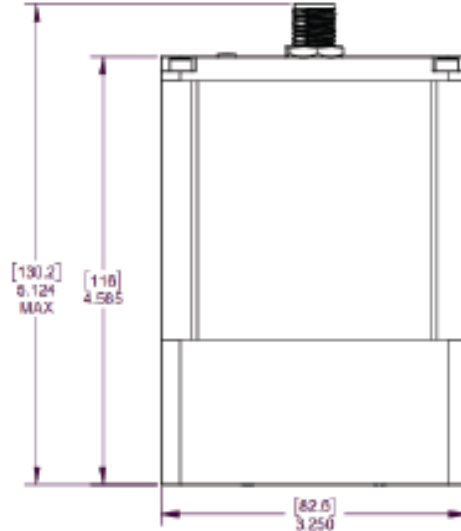

USB
No Relief Valve

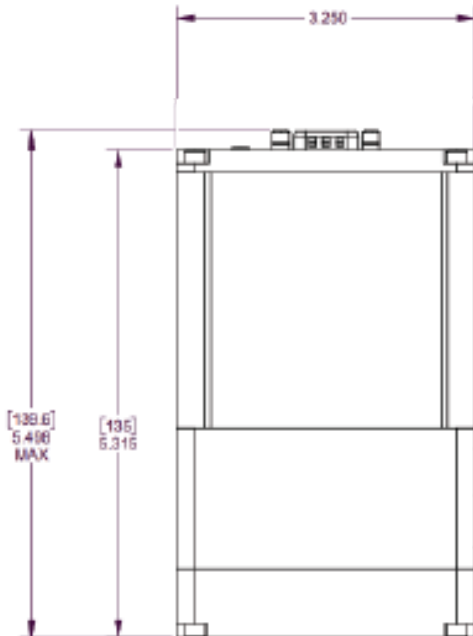

RS-232/RS-485
With Relief Valve

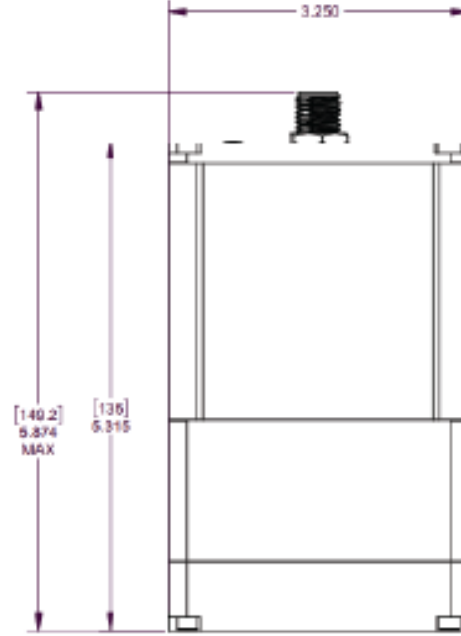

USB
With Relief Valve

0020962001A 09/2025 EN

EN

Specifications

Side Profile

With and without relief valve

Note: Opposite side will have same dimensions mirrored over the v-axis

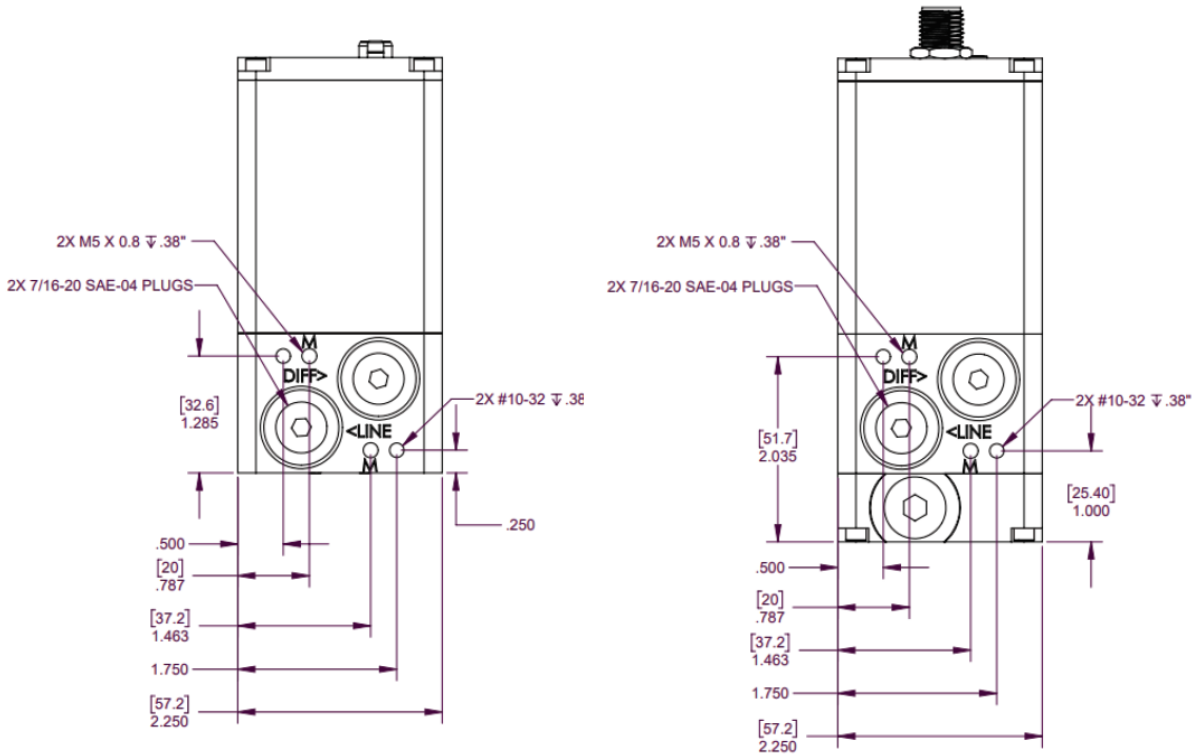

Top Profile

RS-232/RS-485 and USB connection

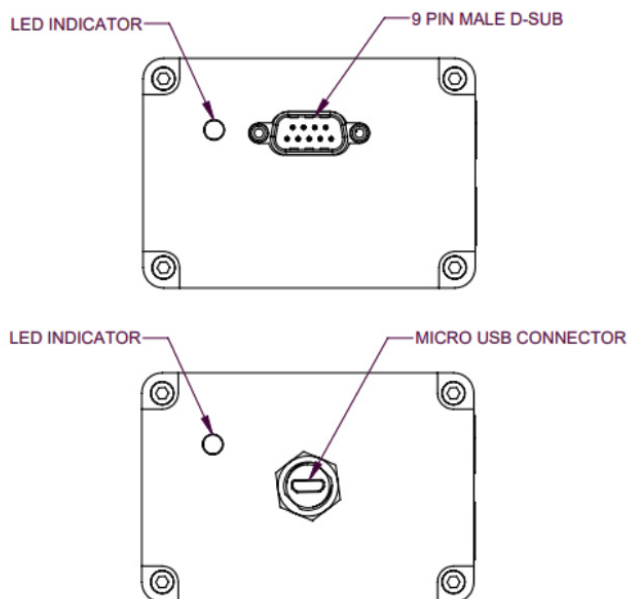

Bottom Profile

Same for both with and without relief valve

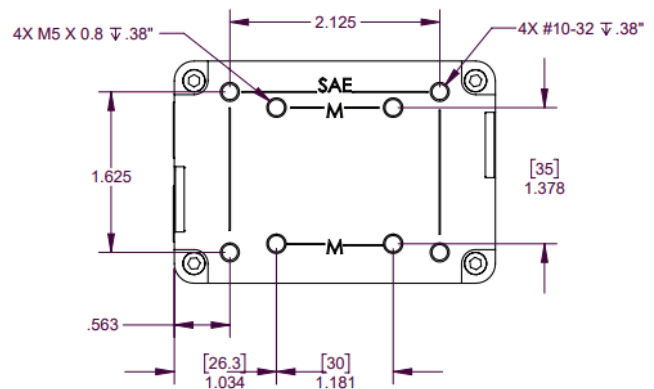

10. Accessories

10.1 Fittings

Mensor supplies a customer specified fitting with each transducer. Available fittings to connect to the transducer have the following Mensor Part numbers:

EN

Part Number	Description
0018203043	7/16-20 SAE male to 6 mm tube
0018203045	7/16-20 SAE male to 1/4" tube
0018203005	7/16-20 SAE male to 1/4" NPT female
0018203001	7/16-20 SAE male to 1/8" NPT female
0018203018	7/16-20 SAE male to 1/8" BSPG female

Many other fittings are available, consult the factory if you need assistance.

10.2 Accessories

Part Number	Description
0020955001	Power supply & RS-232 communication cable
0020955002	Power supply & RS-485 communication cable
4020904001	Micro USB cable, 1 meter
4020904003	Micro USB cable, 3 meters
4060200005	Cable - USB to RS-232 adapter
0018846001	Cable - USB to RS-485 adapter
8200100029	Carrying case
0020752001	Calibration adapter
0020922001	Dual differential relief valve (differential protection only)
0020922002	Dual differential relief valve with relief to atmosphere (static line protection)

WIKA subsidiaries worldwide can be found online at www.wika.com.



Mensor Corporation
201 Barnes Drive
San Marcos, TX 78666 • USA
Tel. (+1) 512 3964200
E-Mail sales@mensor.com
www.mensor.com



WIKAI Alexander Wiegand SE & Co. KG
Alexander-Wiegand-Straße 30
63911 Klingenberg • Germany
Tel. +49 9372 132-0
Fax +49 9372 132-406
info@wika.de
www.wika.de

Imported to UK by:
WIKAI Instruments Ltd,
Unit 6 & 7 Goya Business Park,
The Moor Road, Sevenoaks
Kent, TN15 5GY

0020962001A 09/2025 EN